



# SCORPIO ARM

The Scorpio Arm together with the 5-axis **Scorpio Stabilized Head V** mounted on the 585 horsepower strong **Mercedes AMG GLE 63S** is a phenomenal tool for getting those hard to get shots in a safe and easy way and look good doing it.

The concept of a motorized arm on a car is also commonly known as a "Russian Arm" "U Crane" or "Ultimate Arm" depending of the manufacturer.

We use the Scorpio system from our friends at Servicevision in Barcelona that is built with the same sense for detail and quality as the rest of there product line.

Delivered with a experienced crew:

**Precision Driver - Arm Operator - Camera Operator**

And 6 seats makes sure that everybody can ride along for instant communication:

**DP - Director - AC**



- **Batterybank** built in provides power for all equipment, only change your cards or mags.
- **Shakerbox** built in to the head.
- **Scorpio Focussystem** with 3 Motors or use only 1 for zoom control at the operator and use a WCU for example to control Focus, Iris and Camera.
- **Monitors 10'** and **EarTec Intercoms** for all 6 seats.
- **PIX Recorder** for instant playback on all monitors.
- **Joysticks** or **CrankWheels** operates the camera.



## THE CREW

The most important part of the setup is of course the people operating it.

We always provide you with a experienced and well trained team that has many years of experience in film production, not only with the car but also as Key Grips, Gaffers and Operators which gives them a deeper understanding for the shots.

They handle the safety briefings with the rest of the production and the communication with safety crew and other vehicles during shoot.

Or use us as a self contained Second Unit for running shots or plates for example.

We can also provide Precision Drivers that we are used to working with to make the time on set spent in the most efficient way possible.



## THE PRODUCTIONS

We have shot on numerous Feature Films, TV Series and Commercials:

Netflix - HBO - Viasat - FLX - SVT - HeyFilm - ArcLights - Kanal75 - NEP...

And of course the car commercials:

Volkswagen - Porsche - Audi - Koenigsegg - Hyundai - Opel - Redbull F1 - Skoda  
JEEP - Peugeot - Volvo - SEAT - BMW - Scania - Renault

And more...



## THE PRICES

The package for one 8 hour day of shooting in Stockholm is:

**46 700 SEK** ( About 4000 EUR - 2023 06 12 )

### That includes

Car - Arm - Head - Driver - Arm Operator - 50L fuel - 4h Prep - Transport within Stockholm.  
( Production DP operates the camera )

Basically what you need to add is the camera equipment and lens and then you are ready to shoot.

### Things you can add

• Camera Operator	<b>8500 SEK 8 Hours</b>	( 730 EUR )
• Precision Driver (HeroCar)	<b>8500 SEK 8 Hours</b>	( 730 EUR )
• 360° Continuous Roll Nodal Ring	<b>2500 SEK</b>	( 215 EUR )
• Raindeflector	<b>1500 SEK</b>	( 130 EUR )
• 4G System for live view anywhere	Price on demand	
• Transport outside of Stockholm	Price on demand	
• Fuel over <b>50</b> liters		
• Overtime		
• Superstudded tires for driving on ice		

### Costs for crew outside the 8 hour package, per crew member

Hours 9 -10	<b>1214 SEK / Hour</b>	( 105 EUR / Hour )
Hours 11-12	<b>1700 SEK / Hour</b>	( 145 EUR / Hour )
Hours 13 ->	<b>2833 SEK / Hour</b>	( 245 EUR / Hour )

• TechRecce 8 hours	<b>6000 SEK</b>	( 515 EUR )
• Prepdag	<b>6000 SEK</b>	( 515 EUR )
• Traveldag	<b>4250 SEK</b>	( 365 EUR )

### When not in Stockholm

When going outside of Stockholm there is extra transport and travel costs that can differ a lot depending on where the shoot is so just contact us for a more detailed quote.

# THE CAR

## Engine

AMG 5,5 Liter  
BiTurbo V8  
585 hp / 430 kW  
760 Nm of Torque

## 0-100 km/h

4,2 sec (no arm)

## Top Speed

250 km/h (no arm)

## Height

9,2 feet / 2,8 m

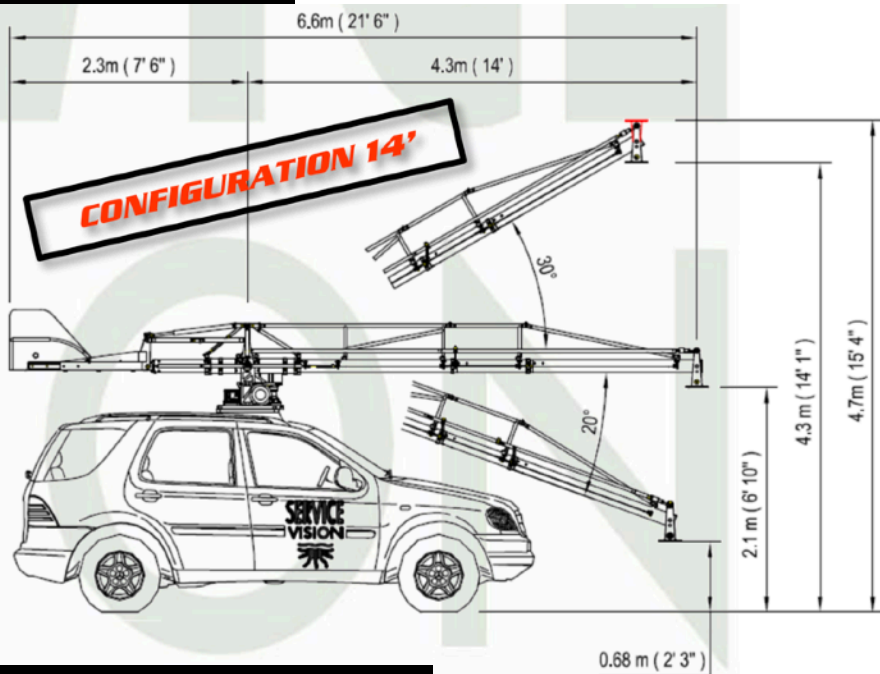
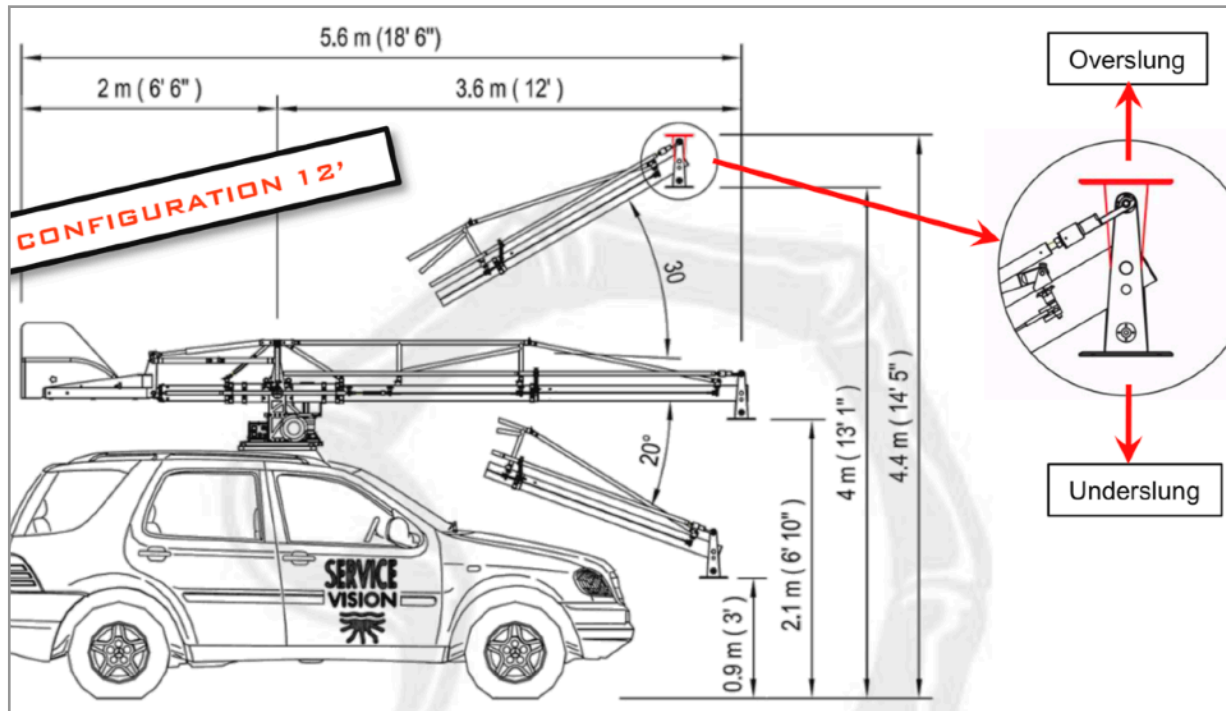

# THE ARM

Controlled with Joysticks.  
Gyrostabilized Tiltaxis

## Configurations

12 feet / 3,6 meters

14 feet / 4,3 meters

18,5 feet / 5,6 meters

Can be changed on location

## Speed

360° Pan - 5,5 Seconds

## Max Payload

154 lbs / 70 kg

# THE HEAD

## Pan

360° Continuous

## Tilt

270°

## Roll

+/- 30° or 360° Continuous  
Roll Nodal Ring (Optional)

## Speed

360° Pan - 2.8 Seconds

## Max Payload

99 lbs / 45 kg

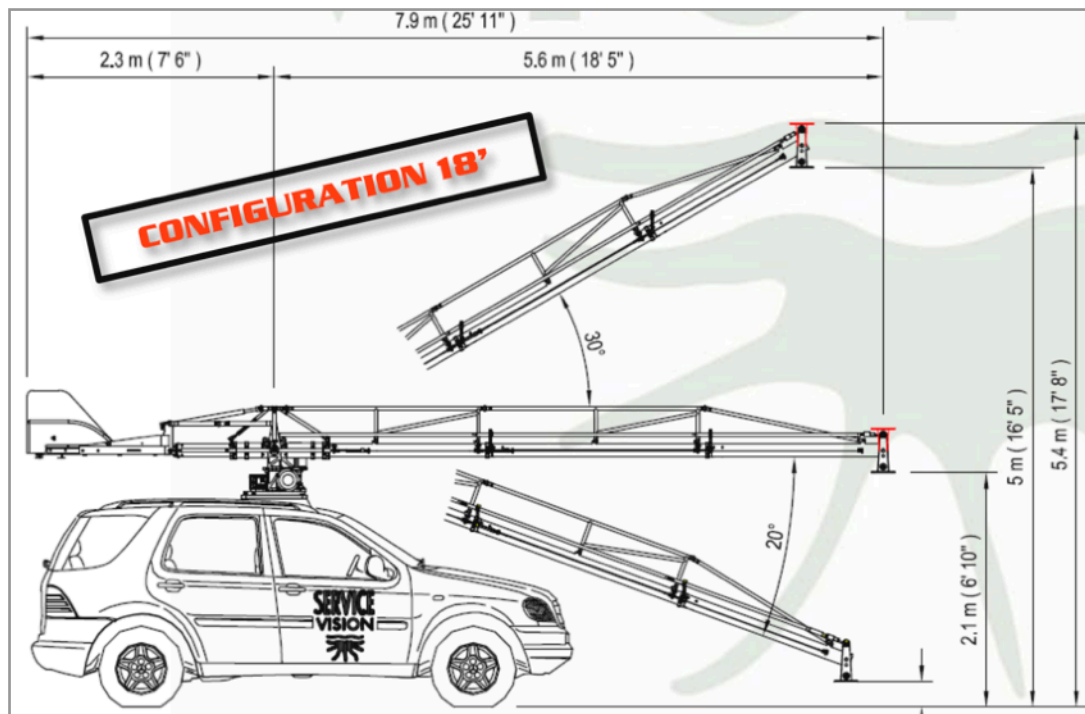



## THE TRANSPORT

We have a few different options for transport. For longer trips it can go in it's own truck, stays dry and safe and there is room to bring the camera equipment as well as some smaller Grip equipment.

For shorter trips the car itself can pull a trailer with the needed equipment and just park the trailer at basecamp.

We have done productions in:

Sweden - Denmark - Norway - Finland  
Estonia - Lithuania - Latvia - Spain -  
Portugal and The Faroe Islands and can help  
you wherever your production takes us.



## THE OPTIONS

Instead of the crane arm you can also use the car as a rigging platform with a Panther Tower or a 150 mm Column, front or back with a remotehead of your choice. Use a Towdolly or Lowloader, whatever fits your needs and budget.

Arri, Sony, RED, Blackmagic or Panavision.  
We come prepared with cables and more for any camera.

Of course we can also bring camera, lenses, lights or whatever else you could need for your production and ordered together with the car you get a 30% discount.

# THE COMPANY

Specialized in Film Equipment Rental since 1992  
Camera, Audio, Light, Grip and Stills Equipment at one location



Ljud & Bildmedia AB is dedicated to provide you with one of the widest range of professional production equipment in northern Europe, regardless of production size or recording format.

In our rental inventory you will find anything from generator trucks and telescopic camera cranes to some of the world's most advanced cinema cameras and accessories to complement them.

Along our rental operations, we have a constantly growing stock of items for sale and a service department that maintains and repairs our own equipment as well as yours.



## Phone

Mobile +46 730 60 66 01  
Office +46 8 540 279 26



## Website

[www.ljud-bildmedia.se](http://www.ljud-bildmedia.se)



## Email

[karl@ljud-bildmedia.se](mailto:karl@ljud-bildmedia.se)  
[info@ljud-bildmedia.se](mailto:info@ljud-bildmedia.se)



## Instagram

[@ljudbildmedia](https://www.instagram.com/ljudbildmedia)



## Visiting Address

Voltavägen 9  
168 69 Bromma  
Stockholm, Sweden



## Facebook

Ljud & Bildmedia AB